

GW approach to Anderson model out of equilibrium: Coulomb blockade and false hysteresis in the I - V characteristics

Catalin D. Spataru,^{1,2} Mark S. Hybertsen,³ Steven G. Louie,^{4,5} and Andrew J. Millis⁶¹*Center for Electron Transport in Molecular Nanostructures and Center for Integrated Science and Engineering, Columbia University, New York, New York 10027, USA*²*Sandia National Laboratories, Livermore, California 94551, USA*³*Center for Functional Nanomaterials, Brookhaven National Laboratory, Upton, New York 11973, USA*⁴*Department of Physics, University of California at Berkeley, Berkeley, California 94720, USA*⁵*Materials Sciences Division, Lawrence Berkeley National Laboratory, Berkeley, California 94720, USA*⁶*Department of Physics, Columbia University, New York, New York 10027, USA*

(Received 23 December 2008; revised manuscript received 3 March 2009; published 15 April 2009)

The Anderson model for a single impurity coupled to two leads is studied using the GW approximation in the strong electron-electron interaction regime as a function of the alignment of the impurity level relative to the chemical potentials in the leads. We employ a nonequilibrium Green's function technique to calculate the electron self-energy, the spin density, and the current as a function of bias across the junction. In addition we develop an expression for the change in the expectation value of the energy of the system that results when the impurity is coupled to the leads, including the role of Coulomb interactions through the electron self-energy in the region of the junction. The current-voltage characteristics calculated within the GW approximation exhibit Coulomb blockade. Depending on the gate voltage and applied bias, we find that there can be more than one steady-state solution for the system, which may give rise to a hysteresis in the I - V characteristics. We show that the hysteresis is an artifact of the GW approximation and would not survive if quantum fluctuations beyond the GW approximation are included.

DOI: [10.1103/PhysRevB.79.155110](https://doi.org/10.1103/PhysRevB.79.155110)

PACS number(s): 72.10.-d, 71.10.-w, 73.23.Hk, 73.63.-b

I. INTRODUCTION

Transport through nanoscale junctions poses a number of interesting physical problems. In particular, electron-electron interaction effects may be important, as evidenced by the observation of phenomena such as the Coulomb blockade and the Kondo effect.^{1,2} The local electronic structure is also important. The energy and character of the electronic states in the junction region that are responsible for electron transport will depend on the details of bonding between the molecule and the electrode. This has motivated the use of *ab initio* theories for electron transport through nanostructures that are based on density-functional theory (DFT). However, local-density functionals do not treat the discreteness of charge properly.^{3,4} In particular Coulomb blockade phenomena become problematic. Even on the level of model systems, a complete solution of the nonequilibrium interacting electron problem is not available. The numerical methods which work so well in equilibrium are only beginning to be applied to nonequilibrium systems.⁵⁻¹² Many groups are exploring self-consistent perturbative and other nonperturbative approaches¹³⁻²⁰ However, a complete treatment which can be extended to incorporate actual junction-specific aspects is not yet available.

In this work, we study a model system, namely, the single impurity Anderson model²¹ coupled to two leads. We use a Green's function approach to calculate the properties of the junction, both in equilibrium and as a function of applied bias across the junction. The electron-electron interactions are incorporated through the electron self-energy operator on the impurity, using an out-of-equilibrium generalization of the GW approximation.²² Using this approach we can calcu-

late the local spin density in the junction and the current as a function of bias. In addition we develop and apply an extension to nonzero bias of the usual expression²³ for the change in the average energy of the impurity due to coupling to the leads. The GW approximation has been widely and successfully used to study electronic excitations in materials at equilibrium with a realistic atomic scale description.²⁴⁻²⁸ This is one of the motivations to study the out-of-equilibrium generalization for nanoscale junctions.¹⁴⁻¹⁷ In particular, the intermediate coupling/interaction regime of the single impurity Anderson model has recently been studied using the GW approximation.^{15,16}

We are interested in the intermediate to strong-coupling regime, in which Coulomb blockade effects are important. At equilibrium and for zero temperature, as the local Coulomb interaction on the impurity is increased (relative to the hybridization with the leads), a local-moment forms. In the limit of $k_B T \rightarrow 0$ and vanishing bias, the local moment on the impurity is quenched through formation of a singlet ground state. The spectral function splits into three parts: two Hubbard bands and one central Kondo peak. In a closely related earlier study,²⁹ it was shown that in the regime of intermediate strength of the Coulomb interaction, the GW approximation provides an incorrect representation of the linear-response conductance. In fact, this regime is not well described at equilibrium even by more sophisticated perturbative approaches, such as the fluctuation-exchange approximation.^{30,31} Here we probe the strong-coupling Coulomb blockade regime. In this regime, the Kondo temperature T_K becomes very small and at experimentally relevant temperature scales the Kondo peak will be washed out. Similarly, when considering bias large compared to the Kondo

temperature, the Kondo peak also gets washed out.^{32,33} In these regimes a self-consistent perturbative approach may be adequate. We find through nonequilibrium calculations that the self-consistent GW approximation can describe important features of the Coulomb blockade regime, such as the Coulomb diamond signature with no Kondo-assisted tunneling, in accordance with experiments on single-molecule transistors characterized by weak effective coupling between molecule and electrodes.¹

The nonequilibrium GW calculations exhibit hysteresis in the I - V characteristics: at some values of applied bias and gate voltage, there is more than one steady-state solution. A related example of bistability has been found in DFT calculations of a junction involving an organometallic molecule.³⁴ However, we believe that in the problem that we study here, the hysteresis is an artifact of the approximation.¹⁸ In fundamental terms, a molecular junction is a quantum field theory in zero space and one time dimension. Model system calculations^{18,19} have confirmed that departures from equilibrium act as an effective temperature which allows the system to explore all of its phase space, preventing bistability from occurring. We will show by an energy calculation that in the present problem similar processes exist.

The rest of the paper is organized as follows. In Sec. II, the model Hamiltonian is described. Section III presents the nonequilibrium self-consistent Green's function approach that we use, including the GW approximation, an expression for the change in the average energy, as well as an expression for the current that allows distinguishing of the Landauer-type and the noncoherent contributions. The results of the calculations for the single impurity Anderson model are developed in Sec. IV. Derivations of the expressions for the physical observables appear in Appendixes A and C.

II. MODEL HAMILTONIAN

We consider the Anderson model for an impurity coupled symmetrically to noninteracting leads. We are interested in steady-state solutions of this system. The Hamiltonian describing the system, H , can be written as a sum of a noninteracting part, H_0 , plus an interacting one, H_{e-e} , describing the electron-electron interaction in the impurity: $H=H_0+H_{e-e}$.

The noninteracting part is treated at the tight-binding level [Fig. 1(a)]. The left (L) and right (R) leads are modeled as semi-infinite chains of atoms ($i=1, \dots, \infty$ or $-1, \dots, -\infty$), characterized by the hopping parameter t and chemical potentials μ_L and μ_R . We choose $t=5$, resulting in the bandwidth of the metallic leads extending to ± 10 about the chemical potential of each lead which we fix at the center of each electrode band. The system is driven out of equilibrium by applying a source-drain bias voltage V , setting $\mu_L=-\mu_R=V/2$; the impurity levels can also be shifted according to a gate voltage V_G [Fig. 1(b)]. The hybridization term describes the coupling between the impurity (site 0) and the nearest atoms of the two leads (sites ± 1), and is parametrized according to the hopping parameter γ .

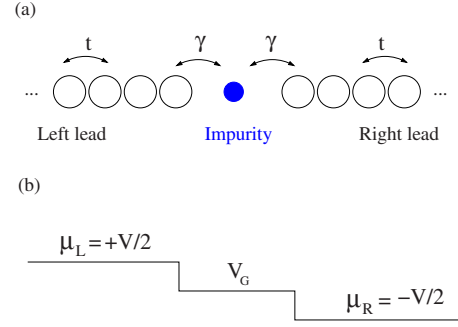

FIG. 1. (Color online) Schematic view of the Anderson impurity model system considered. (a) Tight-binding model for the noninteracting system. (b) Definition of applied source-drain bias V and gate voltage V_G .

$$H_0 = \mu_L N_L + \mu_R N_R + V_G n_0 - t \left(\sum_{i=-\infty}^{-2} + \sum_{i=1}^{\infty} \right) \times \sum_{\sigma} (c_{i\sigma}^{\dagger} c_{i+1\sigma} + c_{i+1\sigma}^{\dagger} c_{i\sigma}) - \gamma \sum_{i=-1,1} \sum_{\sigma} (c_{i\sigma}^{\dagger} c_{0\sigma} + c_{0\sigma}^{\dagger} c_{i\sigma}), \quad (1)$$

where $N_{L(R)}$ are the electron number operators in the $L(R)$ leads:

$$N_L = \sum_{i=-\infty}^{-1} \sum_{\sigma} c_{i\sigma}^{\dagger} c_{i\sigma}; \quad N_R = \sum_{i=1}^{\infty} \sum_{\sigma} c_{i\sigma}^{\dagger} c_{i\sigma}, \quad (2)$$

and n_0 is the electron number in the impurity:

$$n_0 = \sum_{\sigma} c_{0\sigma}^{\dagger} c_{0\sigma}. \quad (3)$$

The electron-electron interaction inside the impurity is taken into account through the usual U term:

$$H_{e-e} = U n_{0\uparrow} n_{0\downarrow} = \frac{1}{2} \sum_{\alpha, \alpha', \beta, \beta'} c_{0, \alpha}^{\dagger} c_{0, \beta}^{\dagger} \tilde{V}_{\alpha \alpha', \beta \beta'} c_{0, \beta'} c_{0, \alpha'}. \quad (4)$$

There are several choices we can make for the two-particle interaction $\tilde{V}_{\alpha \alpha', \beta \beta'}$. We choose one that describes nonspin-flip scattering:

$$\tilde{V}_{\alpha \alpha', \beta \beta'} = V_{\alpha \beta} \delta_{\alpha \alpha'} \delta_{\beta \beta'}, \quad (5)$$

and has a spin-dependent form:

$$V_{\alpha \beta} = U(1 - \delta_{\alpha \beta}). \quad (6)$$

Another choice for the two-particle interaction, which results in the same Hamiltonian as in Eq. (4) would be one with a spin-independent form: $V_{\alpha \beta} = U$. However, in the context of the GW approximation for the Anderson model, the spin-dependent form is a better choice.²⁹ Indeed, it has been shown that the spurious self-interactions can be a major source of error in transport calculations, especially when the coupling to the leads is weak.⁴ Comparing the two choices for $V_{\alpha \beta}$, the spin-dependent one has the advantage of being free of self-interaction effects, and it also accounts for more quantum fluctuations in the spin-spin channel.²⁹

In the present model, the potential due to the applied source-drain bias V and gate voltage V_G changes only at the junction contacts [Fig. 1(b)]. Also, the direct electron-electron interaction between the impurity and the leads is neglected. These approximations are justified in realistic systems in which the screening length in the leads is very short. We are interested in the limit of very small effective coupling to the leads $\Gamma \equiv 2\gamma^2/t$. Our choices $\gamma=0.35$ and $t=5$ imply $\Gamma=0.05$. The on-site Coulomb repulsion between a spin-up and a spin-down impurity electron is set to $U=4.78 \approx 100\Gamma$. At equilibrium and half filling, the Kondo temperature T_K is then³⁵:

$$T_K \approx 0.2\sqrt{2\Gamma U} \exp(-\pi U/8\Gamma), \quad (7)$$

which is thus negligibly small. The results that we present for this set of parameters hold, qualitatively, for a wide range of parameters consistent with a weak hybridization and strong Coulomb interaction regime.

III. SELF-CONSISTENT NONEQUILIBRIUM GREEN'S FUNCTION FORMALISM

A. Hamiltonian and basic formalism

Electron correlation effects in the impurity are studied using a nonequilibrium Green's function formalism by solving self-consistently for the various [retarded (r), advanced (a), lesser ($<$) and greater ($>$)] Green's functions of the impurity^{36,37}:

$$G^r(\omega) = [(\omega - V_G)I - \Delta_L^r(\omega) - \Delta_R^r(\omega) - V^H - \Sigma^r(\omega)]^{-1}, \quad (8)$$

$$G^<(\omega) = G^r(\omega)[if_L(\omega)\Gamma_L(\omega) + if_R(\omega)\Gamma_R(\omega) + \Sigma^<(\omega)]G^a(\omega), \quad (9)$$

where all quantities are matrices in the space spanned by the junction degrees of freedom, in the present case the up and down components of the impurity spin.³⁸

Above, Δ^r stands for the retarded lead self-energy, which, for our model Hamiltonian, takes the form³⁹:

$$\Delta_{L(R)}^r(\omega) = I \frac{\gamma^2}{2t^2} \times \begin{cases} \omega - \mu_{L(R)} - \sqrt{(\omega - \mu_{L(R)})^2 - 4t^2}, & \omega - \mu_{L(R)} > 2t \\ \omega - \mu_{L(R)} - i\sqrt{4t^2 - (\omega - \mu_{L(R)})^2}, & |\omega - \mu_{L(R)}| \leq 2t \\ \omega - \mu_{L(R)} + \sqrt{(\omega - \mu_{L(R)})^2 - 4t^2}, & \omega - \mu_{L(R)} < -2t \end{cases} \quad (10)$$

where I is the unity matrix in spin space, and we have used the notation:

$$\Gamma_{L(R)}(\omega) \equiv i[\Delta_{L(R)}^r(\omega) - \Delta_{L(R)}^r(\omega)^\dagger]. \quad (11)$$

The hybridization functions $\Delta_{L(R)}$ are centered on the chemical potentials $\mu_{L(R)}$, such that the isolated leads are neutral.

V^H represents the Hartree potential:

$$V_{\sigma\sigma'}^H = \delta_{\sigma\sigma'} \sum_{\sigma''} \int \frac{dE}{2\pi} (-i)G_{\sigma''\sigma''}^<(E)V_{\sigma''\sigma}, \quad (12)$$

and Σ^r ($\Sigma^<$) is the retarded (lesser) impurity self-energy, describing the effects of electron correlation inside the junction. The electron occupation numbers appearing in Eq. (9) are the usual statistical factors for a system of electrons: $f_{L(R)}(\omega) = 1/\{\exp[(\omega - \mu_{L(R)})/k_B T] + 1\}$. Since we operate in the regime of very small Kondo temperature, we envision choosing an experimentally relevant temperature that is large compared to T_K but which is much smaller than the coupling to the electrodes.

The other two nonequilibrium impurity Green's functions can be simply obtained using:

$$G^a(\omega) = G^r(\omega)^\dagger, \quad (13)$$

$$G^>(\omega) = G^r(\omega) - G^a(\omega) + G^<(\omega). \quad (14)$$

B. GW approximation for the impurity self-energy

In the GW approximation for the electron self-energy, one does perturbation theory in terms of the screened interaction W , keeping the first term in the expansion, the so-called GW diagram. The GW approximation has long been successfully used in describing the equilibrium quasiparticle properties of real materials.²⁴⁻²⁸ It has also been applied to the study of real materials out of equilibrium, such as highly irradiated semiconductors,⁴⁰ or, more recently, in transport calculations through molecular nanojunctions.^{14,15,17} For equilibrium properties the GW approximation has been compared to a numerically exact quantum Monte Carlo treatment²⁹; it has been found to be adequate for small interactions or for high T , but not in the mixed valence or Kondo regimes.

Within the out-of-equilibrium GW approximation, the general self-energy expressions have the following form in frequency space⁴⁰:

$$\begin{aligned} \Sigma_{\sigma\sigma'}^r(\omega) = & i \int \frac{dE}{2\pi} G_{\sigma\sigma'}^<(E)W_{\sigma\sigma'}^r(\omega - E) \\ & + i \int \frac{dE}{2\pi} G_{\sigma\sigma'}^r(E)W_{\sigma\sigma'}^>(\omega - E), \end{aligned} \quad (15)$$

$$\Sigma_{\sigma\sigma'}^<(\omega) = i \int \frac{dE}{2\pi} G_{\sigma\sigma'}^<(E) W_{\sigma\sigma'}^<(\omega - E), \quad (16)$$

where the screened interaction W can be obtained from the irreducible polarizability P through

$$W^r(\omega) = [I - VP^r(\omega)]^{-1}V, \quad (17)$$

$$W^<(\omega) = W^r(\omega)P^<(\omega)W^a(\omega), \quad (18)$$

$$W^>(\omega) = W^r(\omega)P^>(\omega)W^a(\omega). \quad (19)$$

The irreducible polarization P is evaluated in the random-phase approximation (RPA):

$$P_{\sigma\sigma'}^r(\omega) = -i \int \frac{dE}{2\pi} G_{\sigma\sigma'}^r(E) G_{\sigma'\sigma}^<(E - \omega) - i \int \frac{dE}{2\pi} G_{\sigma\sigma'}^<(E) G_{\sigma'\sigma}^a(E - \omega), \quad (20)$$

$$P_{\sigma\sigma'}^a(\omega) = -i \int \frac{dE}{2\pi} G_{\sigma\sigma'}^a(E) G_{\sigma'\sigma}^<(E - \omega) - i \int \frac{dE}{2\pi} G_{\sigma\sigma'}^<(E) G_{\sigma'\sigma}^r(E - \omega), \quad (21)$$

$$P_{\sigma\sigma'}^<(\omega) = -i \int \frac{dE}{2\pi} G_{\sigma\sigma'}^<(E) G_{\sigma'\sigma}^>(E - \omega). \quad (22)$$

Setting $P=0$ yields the Hartree-Fock approximation.

The set of equations for G , Σ , W , and P are solved to self-consistency, starting from an initial condition for G . All the quantities are calculated on a real frequency grid (either regular or log scale), with a ω range up to $\pm 10t$. Real and imaginary parts of the various quantities are calculated explicitly, making sure that the retarded functions obey the Kramers-Kronig relation. In order to speed up the self-consistent process, we employ the Pulay scheme to mix the

Green's functions using previous iterations solutions^{16,41}:

$$\mathcal{G}_{\text{in}}^{j+1} = (1 - \alpha)\bar{\mathcal{G}}_{\text{in}}^j + \alpha\bar{\mathcal{G}}_{\text{out}}^j, \quad (23)$$

where $\bar{\mathcal{G}}^n$ are constructed from the previous m iterations:

$$\bar{\mathcal{G}}^j = \sum_{i=1}^m \beta_i \mathcal{G}^{j-m+i}, \quad (24)$$

and we choose three components for the parameter vector \mathcal{G} : $\Re G^r$, $\Im G^r$, and $\Im G^<$. The values of β_i are obtained by minimizing the distance between $\bar{\mathcal{G}}_{\text{in}}^j$ and $\bar{\mathcal{G}}_{\text{out}}^j$. The scalar product in the parameter space is defined using the integral in Fourier space of a product of the component Green's functions. We found the speed of the convergence process to be quite independent on the choice of reasonable values for m , as well as on the number of components for the parameter vector \mathcal{G} . As for the parameter α , smaller values (<0.1) were needed for small bias voltages ($V < 0.5$), while $\alpha=0.4$ was sufficient in order to achieve fast convergence for larger biases.

C. Relation to physical observables

The Green's functions of the impurity can be used to extract information about observables pertaining to the impurity or even to the leads. Thus, the spectral function of the impurity $A(\omega)$ is simply related to the retarded Green's function:

$$A(\omega) = -\frac{1}{\pi} \text{Tr} \Im G^r(\omega), \quad (25)$$

where Tr stands for trace over the impurity spin degrees of freedom. Also, the average impurity spin occupation number is

$$\langle n_{0,\sigma} \rangle = \int \frac{d\omega}{2\pi i} G_{\sigma\sigma}^<(\omega). \quad (26)$$

The expression for the average current passing through the junction is given by the general Meir-Wingreen expression,⁴² which can be recast as (see Appendix A for the derivation):

$$I = \int d\omega [f_L(\omega) - f_R(\omega)] \text{Tr} \{ \Gamma_L(\omega) G^r(\omega) \Gamma_R(\omega) G^a(\omega) \} + \int d\omega \text{Tr} \left\{ [\Gamma_L(\omega) - \Gamma_R(\omega)] G^r(\omega) \left[\frac{i}{2} \Sigma^<(\omega) \right] G^a(\omega) \right\} + \int d\omega \text{Tr} \{ [f_L(\omega) \Gamma_L(\omega) - f_R(\omega) \Gamma_R(\omega)] G^r(\omega) [-\Im \Sigma^r(\omega)] G^a(\omega) \}. \quad (27)$$

The first (Landauer type) term plays an important role whenever correlations beyond the Hartree-Fock level are not considerable. It gives the coherent component of the current. The second term is in general very small for symmetric leads with relatively wide bands, when $\Gamma_L(\omega) \approx \Gamma_R(\omega)$. The last term becomes important when the electron-electron correlation effects are such that $-\Im \Sigma^r \approx \Gamma_{L(R)}$.

Having an expression for the average energy associated with the junction for nonequilibrium can be useful for a number of purposes, including calculation of current dependent forces.⁴³ By formulating this as the difference $\delta\mathcal{E}$ between the average energy of the total system (leads coupled to impurity) and the average energy of the isolated leads, a finite result can be obtained. This can be done starting with

the following expression for the total average energy of the system⁴⁶:

$$\mathcal{E} = \frac{1}{2} \int \frac{d\omega}{2\pi i} \tilde{\text{Tr}}\{(H_0 + \omega I)G^<(\omega)\}, \quad (28)$$

where the trace $\tilde{\text{Tr}}$ is taken over a complete set of states spanning the junction (indices n) and the leads (indices k). Alternatively, an equation of motion approach can be used.²³ We find that the two approaches give the same results. The first approach is presented in Appendix B. Naturally, the energy can be decomposed into three terms, related, respectively, to the average energy of the impurity \mathcal{E}_{imp} , the average energy of interaction between leads and impurity $\mathcal{E}_{\text{imp-leads}}$, and the average energy difference in the leads before and after adding the impurity $\delta\mathcal{E}_{\text{leads}}$:

$$\delta\mathcal{E} = \mathcal{E}_{\text{imp}} + \mathcal{E}_{\text{imp-leads}} + \delta\mathcal{E}_{\text{leads}}, \quad (29)$$

where:

$$\mathcal{E}_{\text{imp}} = \frac{1}{2} \int \frac{d\omega}{2\pi i} (\omega + V_G) \text{Tr}G^<(\omega), \quad (30)$$

$$\begin{aligned} \mathcal{E}_{\text{imp-leads}} = & \int \frac{d\omega}{2\pi i} \text{Tr}\{[\Re\Delta_L^r(\omega) + \Re\Delta_R^r(\omega)] \\ & \times G^<(\omega) - i[f_L(\omega)\Im\Delta_L^r(\omega) + f_R(\omega)\Im\Delta_R^r(\omega)] \\ & \times [G^a(\omega) + G^r(\omega)]\}, \end{aligned} \quad (31)$$

$$\begin{aligned} \delta\mathcal{E}_{\text{leads}} = & \frac{1}{2} \int \frac{d\omega}{2\pi i} \text{Tr}\{[\Re F_L(\omega) + \Re F_R(\omega)]G^<(\omega) \\ & - i[f_L(\omega)\Im F_L(\omega) + f_R(\omega)\Im F_R(\omega)][G^a(\omega) + G^r(\omega)]\}, \end{aligned} \quad (32)$$

with

$$F_{L(R)nm}(\omega) = -\Delta_{L(R)}^r(\omega) - 2\omega \frac{d}{d\omega} \Delta_{L(R)}^r. \quad (33)$$

We note that the average energy change in the two leads is always finite in the steady-state case. A similar statement holds for the average number of electrons displaced in the two leads δN_{leads} (explicit expression in Appendix C).

IV. RESULTS

A. Coulomb blockade

In the weak-coupling/strong-interaction regime, the electron transport through a junction can be blocked due to the charging energy in the junction. Figure 2(a) shows the calculated impurity occupation number $\langle n_0 \rangle = \langle n_{0\uparrow} \rangle + \langle n_{0\downarrow} \rangle$ as a function of the gate voltage V_G , at zero applied bias $V=0$.⁴⁴ One can clearly see the Coulomb staircase. The electron-hole symmetry of the Hamiltonian describing the system, H , insures that the spectral function satisfies $A(\omega; V_G + U/2) = A(-\omega; -V_G - U/2)$. As a consequence, one has $\langle n_0(V_G + U/2) \rangle = 2 - \langle n_0(-V_G - U/2) \rangle$. A similar Coulomb staircase picture can be obtained at the Hartree-Fock approximation level.

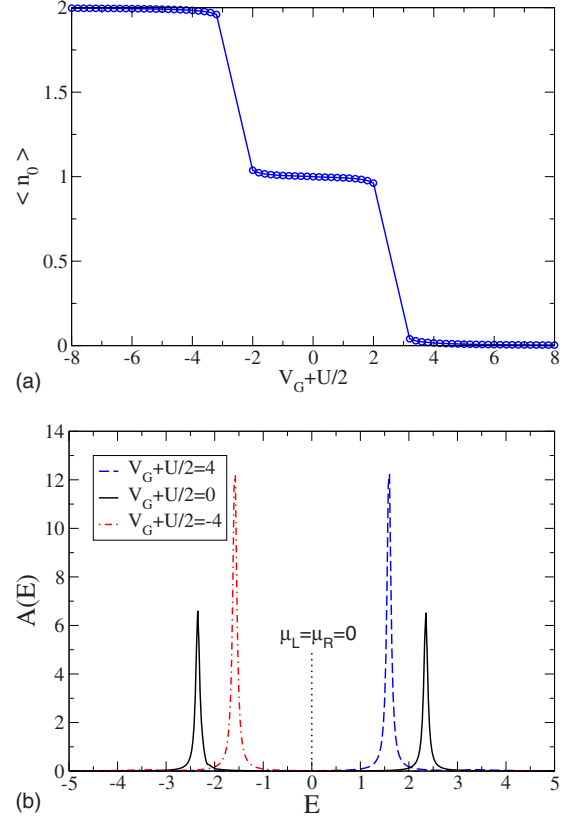

FIG. 2. (Color online) Results for the self-consistent GW approximation at zero applied source-drain bias and $k_B T = 0$. (a) Impurity occupation number as a function of gate voltage. (b) Spectral function for three different values of the gate voltage V_G . Using $U = 4.78$ and $\Gamma = 0.05$.

The impurity occupation number evolves from zero to two as V_G is decreased from positive to negative values. Figure 2(b) shows the evolution of the spectral function for three representative values of V_G . For $V_G + U/2 = \pm 4$, the solution is nonmagnetic, with both spin levels degenerate, empty, or occupied. At the symmetric point (half filling) $V_G + U/2 = 0$, the solution is a broken-symmetry magnetic ground state, with one spin occupied and the other empty. Since we consider temperatures that, although small, are still large compared to T_K , the degenerate magnetic ground state is an appropriate representation of the physics. In Fig. 2(a), the magnetic solution is found for $|V_G + U/2| < 2$; for $2 < |V_G + U/2| < 3$, a well converged (nonmagnetic) solution could not be found at $k_B T = 0$.

Figure 3(a) shows a color-scale plot of the current I as a function of the applied bias V and gate voltage V_G . The plot is obtained by forward scan of the bias, i.e., using the lower bias solution as starting input for the higher bias calculation. One can see the formation of Coulomb diamonds, inside which the current is negligible, a signature of the Coulomb blockade regime. A similar color-scale plot of the differential conductivity would show sharp peaks at the edges of the Coulomb diamonds but no tunneling channel in the zero-bias region inside the central Coulomb diamond. Such a tunneling channel is absent in experiments on single-molecule transistors characterized by weak coupling between molecules and

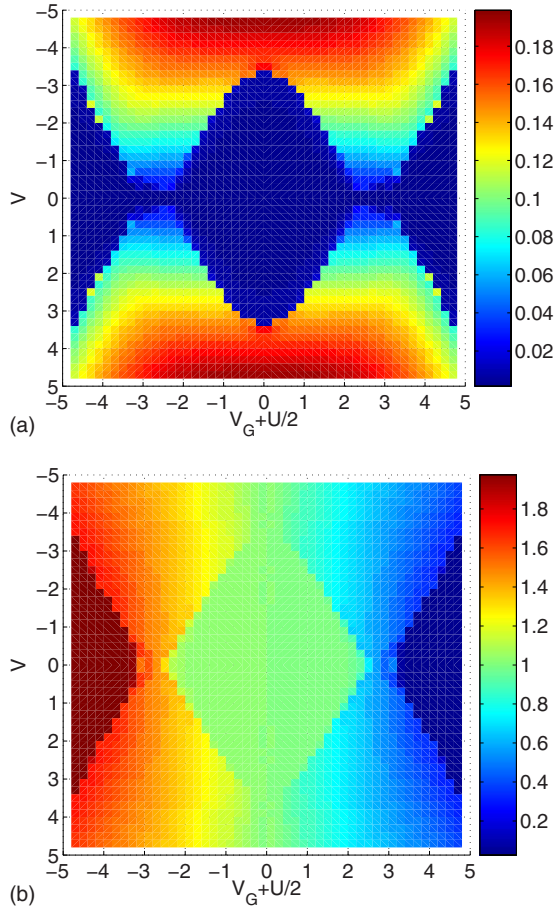

FIG. 3. (Color online) False color plots of junction properties calculated in the self-consistent GW approximation as a function of the applied source-drain bias V and gate voltage V_G at $k_B T = 0$. (a) Current. (b) Average impurity occupation number. Using $U = 4.78$ and $\Gamma = 0.05$.

electrodes¹ but has been observed when coupling to the electrodes is strong enough that the Kondo temperature is appreciable $T_K \sim 10\text{--}30$ meV.^{1,2}

At zero bias, zero temperature, and at the symmetric point, the unitarity limit⁴⁷ requires that the differential conductivity equals $2e^2/h$. The broken (magnetic) symmetry solution in the GW approximation in the strong-interaction regime does not satisfy the unitarity limit; the spectral function does not have the correct height near the chemical potential. Therefore, the GW approximation cannot account for the zero-bias tunneling channel observed for $T < T_K$. Under finite bias, the differential conductance due to the Kondo peaks in the spectral function must fall off once the bias exceeds the Kondo temperature³²; the Kondo peak splits under nonzero bias, following the two different chemical potentials and broadens quickly with increasing bias. Therefore, the width in applied bias for which such a channel would be observed in the exact theory is of order T_K . For the strong-interaction regime considered here, this is negligible. Thus, the GW approximation provides the correct qualitative features of the Coulomb blockade regime, namely, Coulomb diamonds with no Kondo-assisted conductance channels.

The size of the Coulomb diamond depends on the interplay between the repulsion U and the coupling to the leads,

Γ . In the limit of $U/\Gamma \rightarrow \infty$ the system becomes effectively an isolated ion, and the size of the diamond is set by U . In our case, $U/\Gamma \approx 100$ and the computed size of the Coulomb diamond is only slightly smaller (by $\approx 20\%$) in the GW approximation than in the Hartree-Fock approximation. However, we suspect that the magnetic solution found in the GW approximation underestimates the electronic correlation originating from spin-spin quantum fluctuations, and thus a more exact theory should result in smaller size Coulomb diamonds than the ones we find.

The corresponding average electron occupation number $\langle n_0 \rangle$ is shown in Fig. 3(b), where we can see that $\langle n_0 \rangle$ takes integer values of 0, 1, and 2 inside the Coulomb diamonds. For a given gate voltage, the spectral function of the system changes appreciably only when the left or right lead Fermi levels get closer to one of the impurity resonance levels. As soon as a resonant level is pinned by a Fermi level, the current increases while the impurity occupation number either increases or decreases depending whether the pinned level is empty or occupied.

B. Hysteresis in the I - V characteristics

In an earlier study²⁹ we concluded that, in the regime of intermediate strength of the Coulomb interaction, the GW approximation leads to a broken spin symmetry ground state and thus fails to describe the spectral function correctly, missing completely the Kondo peak. A nonmagnetic solution in the interaction regime $U/\Gamma > 8$ has been elusive for other authors as well.¹⁶ Recently, by employing a logarithmic frequency scale near the Fermi level, we have been able to find a nonmagnetic solution in the strong-interaction regime up to $U/\Gamma \approx 25$ and $k_B T = 0$. Our results⁴⁵ show that equilibrium properties of the Anderson model, such as the total energy, Kondo temperature, T -linear coefficient of the specific heat or linear-response conductance, are not satisfactorily described by the nonmagnetic solution in the GW approximation, as it was previously noted for several of these properties.^{29,30}

For the interaction strength considered in the present work, $U/\Gamma \approx 100$, we have been able to calculate the nonmagnetic solution at zero bias by considering small nonzero temperatures. We will consider $k_B T = 0.01$ throughout the rest of the paper. Figure 4(a) shows the impurity occupation number as a function of gate voltage for the nonmagnetic solution. We see that the Coulomb blockade plateau is not properly described; the impurity occupation number changes linearly about the symmetric point $V_G + U/2 = 0$. Figure 4(b) shows the spectral function associated with the nonmagnetic solution for two representative cases. In the symmetric case, one sees a broad peak (whose width is set by U) with a narrow portion near $E = 0$ (whose width is set by $k_B T$). As the gate voltage is changed from the symmetric point, the narrow portion remains pinned near $E = 0$ but the broad peak shifts together with V_G , hence the linear change in $\langle n_{\text{occ}} \rangle$ as observed in Fig. 4(a). Near $V_G + U/2 = \pm 2.8$, the nonmagnetic solution cannot sustain a narrow portion near $E = 0$, and the solution jumps into a phase with one narrow peak (of width $\sim \Gamma$) away from $E = 0$ [as seen in Fig. 2(b) for V_G

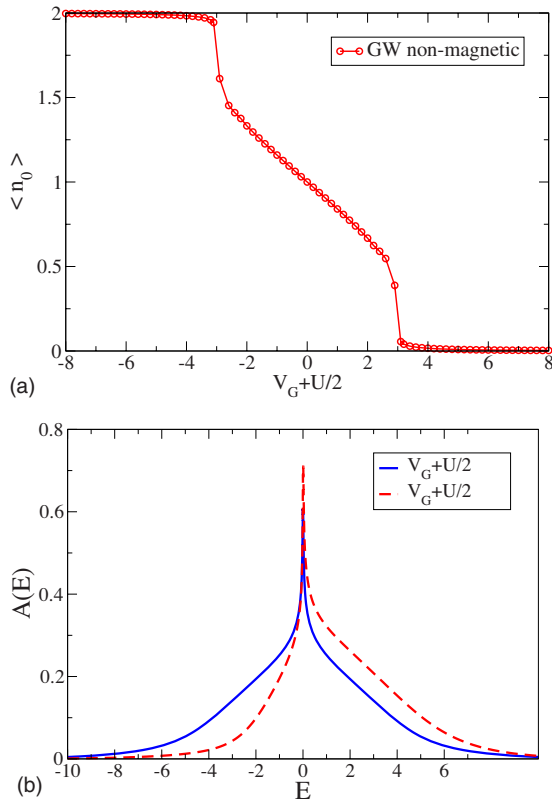

FIG. 4. (Color online) Results for a nonmagnetic solution throughout the gate bias range in the GW approximation at zero source-drain bias and $k_B T = 0.01$. (a) Impurity occupation number as a function of gate voltage. (b) Spectral function for two values of gate voltage, the symmetric case and an asymmetric case. Using $U = 4.78$ and $\Gamma = 0.05$.

$+U/2 = 4$]. In the region of gate bias near the transition at $V_G + U/2 = \pm 2.8$, the calculations get increasingly difficult to converge; for some values of the gate voltage a converged solution with retarded functions obeying the Kramers-Kronig relation could not be found.

Figure 5(a) shows the current through the junction I as a function of the applied bias V for a specific gate voltage V_G , $V_G + U/2 = 0$ such that the system is at half filling, $\langle n_0 \rangle = 1$. The general results do not depend on this symmetry. The same qualitative results hold for a broad range of gate bias $|V_G + U/2| < 2$. Results obtained both in the GW and Hartree-Fock approximations are shown. These include a forward scan, starting from zero applied bias, and a reverse scan starting from $V = 8$. At zero bias, we start with the magnetic solution, with one spin level occupied and the other one empty, as shown by the solid-line curve of Fig. 2(b). Then in the forward scan, the initial input at higher bias is taken from the converged solution at lower bias. For the reverse scan, the opposite approach is taken. Note that the use of $k_B T = 0.01$ has essentially no effect on the results except for the reverse scan with $V < 0.5$ where the finite temperature helps to stabilize the self-consistent magnetic solution. Also, for reference, the I - V data shown in Fig. 3(a) was obtained by forward bias scan.

In both the Hartree-Fock and the GW approximations, as the bias is increased, the two spin levels remain outside the

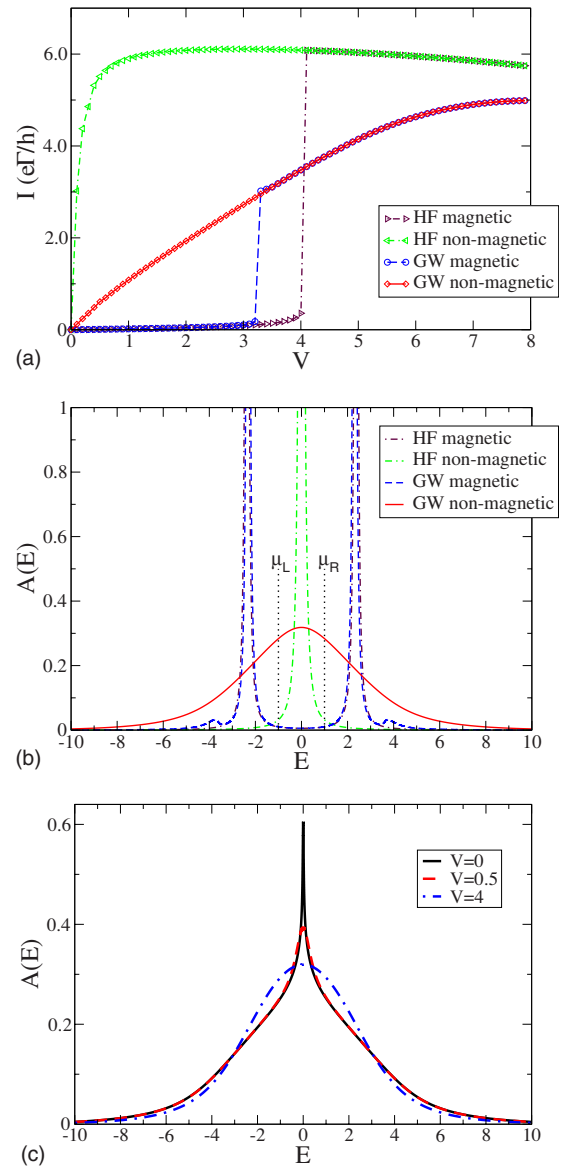

FIG. 5. (Color online) (a) Current as a function of the applied bias for gate voltage fixed to the symmetric case and $k_B T = 0.01$. Curves labeled magnetic correspond to a bias sweep from $V = 0$ to $V = 8$. Curves labeled nonmagnetic correspond to a reverse bias sweep from $V = 8$ to $V = 0$. Results for the Hartree-Fock and GW approximations are compared. (b) Corresponding spectral functions for applied source-drain bias $V = 2$. (c) Comparison of spectral functions for the nonmagnetic solution in the GW approximation at three different applied source-drain bias values. Using $U = 4.78$ and $\Gamma = 0.05$.

bias window and the current is negligible until V approaches a value of order (but less than) U . In Hartree-Fock this value is $V \approx 4.0$ while in GW it is $V \approx 3.2$. At this point, where the broadened impurity levels get pinned by the two chemical potentials, the character of the steady-state solution changes from magnetic to nonmagnetic. At this bias, the current increases suddenly. Correspondingly, the spectral function shows one double-degenerate peak centered half way in between the two chemical potentials [Fig. 5(b)]. For higher bias, the Hartree-Fock and GW approximations result in

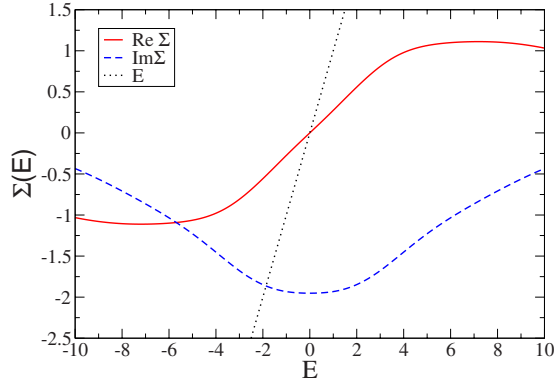

FIG. 6. (Color online) Real and imaginary parts of the retarded self-energy in the GW approximation for the nonmagnetic solution at half filling, applied source-drain bias $V=2$, and $k_B T=0.01$. Using $U=4.78$ and $\Gamma=0.05$.

qualitatively and quantitatively different behaviors. In Hartree-Fock, the current is approximately pinned at the value expected for a single half-filled resonance in the bias window ($2\pi\Gamma e/h$). The overall downward drop is explained by the finite bandwidth of the electrodes. However, in the GW approximation, the spectral function shows substantially larger broadening and the current increases steadily with bias as the spectral weight inside the bias window increases. Correspondingly, upon analysis of contributions to the current in this regime, it is largely due to noncoherent transport, as $-\Im\Sigma^r \gg \Gamma$ and the main component of the current is given by the last term of the right-hand side of Eq. (27). The backward bias scan is started from the nonmagnetic solution at $V=8$. As the bias is decreased, the solution remains nonmagnetic well below the transition bias point from the forward bias scan, resulting in hysteresis in the I - V curve. While, in Hartree-Fock, the current remains high down to relatively low applied bias, the calculated current in the GW approximation drops approximately linearly.

The physical description of the magnetic solution is straightforward. The spectral function shows two peaks [Fig. 5(b)], spin up and spin down, one occupied and the other one empty, separated in frequency by little less than U . The results from the GW approximation are very close to those from Hartree-Fock approximation in this case. There are very few occupied-to-empty electron-hole same-spin excitations; the polarization P is very small.

The nonmagnetic solution is more complex and the physical picture is rather different for the Hartree-Fock and the GW approximations. While, for Hartree-Fock, the spectral function shows only one sharp peak with width equal to Γ , the spectral function in the GW approximation is much broader [Fig. 5(b)]. While the overall broadening depends strongly on the interaction parameter U , the applied bias V affects the region of width V about $E=0$ [Fig. 5(c)]. Furthermore, the width of the spectral function is almost independent of the effective coupling coefficient Γ . For example, for $k_B T=0.01$ and $V \in [0, 8]$, the spectral function plot for $\Gamma=0.1$ is almost undistinguishable from that for the $\Gamma=0.05$ case. This indicates that the broadening is due to quantum fluctuations taking place on the impurity. The applied bias

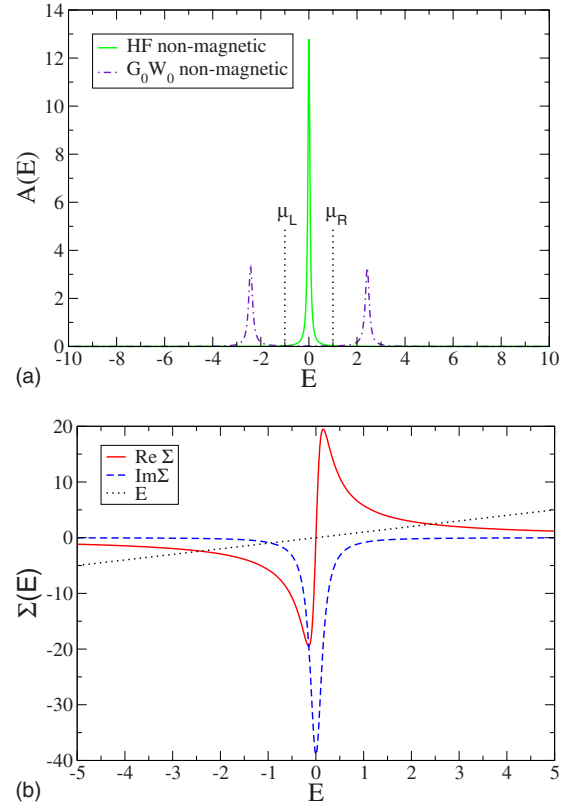

FIG. 7. (Color online) Illustration of steps in the iterative solution to arrive at the final nonmagnetic solution in the GW approximation. Gate voltage fixed to the symmetric (half filling) case, applied source-drain bias $V=2$, and $k_B T=0.01$. (a) Spectral function for the nonmagnetic Hartree-Fock and G_0W_0 solutions. (b) Real and imaginary parts of the retarded nonmagnetic G_0W_0 self-energy. Using $U=4.78$ and $\Gamma=0.05$.

dependent broadening can be traced back to the large imaginary part of the retarded self-energy, as shown in Fig. 6. At zero bias and zero temperature the Fermi-liquid behavior of the system guarantees $\Im\Sigma^r(0)=0$. The nonzero value of $\Im\Sigma^r(0)$ shown in Fig. 6 is clearly a nonequilibrium nonzero bias effect. A similar broadening, increasing strongly with bias, has been also observed in recent calculations based on the GW approximation for a two-level model molecule.¹⁷

The broadening of the spectral function for the nonmagnetic solution in the GW approximation can be understood by looking at how the spectral function and the retarded self-energy changes as we iterate the nonmagnetic solution from Hartree-Fock to GW. Here we denote with G_0W_0 the intermediate solution obtained with the Hartree-Fock Green's functions as input. At the Hartree-Fock level, the nonmagnetic solution has one narrow central peak, with half width at half maximum approximately given by $\Gamma=0.05$. The entire peak is situated inside the bias window, as shown in Fig. 7(a). In that energy range one can find both occupied and empty (more exactly half-occupied) quasistates of the same spin. Now, such a quasistate can easily decay into another quasistate with lower or higher energy by emitting or absorbing an electron-hole same-spin excitation with energy within the bias window range. Thus, $\Im\Sigma^r$, which is proportional to the inverse lifetime of the quasistate, becomes very

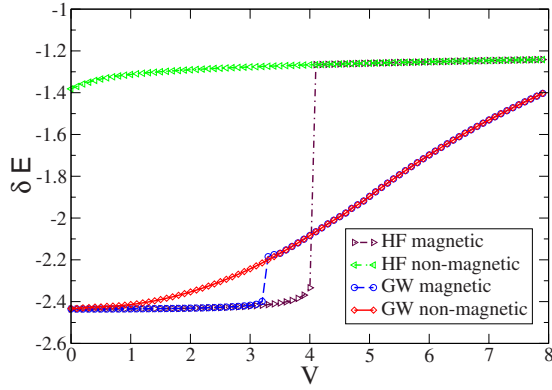

FIG. 8. (Color online) Change in the average energy of the system as a function of applied source-drain bias for gate voltage fixed to the symmetric case (half filling) and $k_B T = 0.01$. Curves labeled magnetic correspond to a bias sweep from $V=0$ to $V=8$. Curves labeled nonmagnetic correspond to a reverse bias sweep from $V=8$ to $V=0$. Results for the Hartree-Fock and GW approximations are compared. Using $U=4.78$ and $\Gamma=0.05$.

large at the G_0W_0 level, as seen in Fig. 7(b). From the G_0W_0 result for $\Re\Sigma^r$ (related to $\Im\Sigma^r$ through a Kramers-Kronig relation), it follows that the G_0W_0 spectral function shows two double-degenerate (spin-up and spin-down) peaks, situated outside the bias window [Fig. 7(a)]. If, at each of the next iterative steps i , we would use as input only the Green's functions from iteration $i-1$, the spectral function would oscillate between the two types (Hartree-Fock and G_0W_0) of solution. However, by means of the Pulay mixing scheme, we are able to achieve convergence rather fast, with the self-consistent GW solution looking somehow in between Hartree-Fock and G_0W_0 , as seen in Fig. 5(b).

The calculated I - V curves in Fig. 5(a) result from the existence of two steady-state solutions over a broad range of applied bias that are accessed depending on initial conditions. Our procedure of stepping the applied bias in forward followed by reverse scans with self-consistent solution at each step simulates an adiabatic voltage scan and the existence of two stable solutions results in hysteresis. One may ask whether quantum fluctuations that are beyond the scope of the GW approximation would eliminate the hysteresis. To probe this, we need to understand the energy difference between the system in the magnetic and the nonmagnetic solutions in the hysteretic region. Figure 8 shows the change in the average energy of the total system, $\delta\mathcal{E}$, calculated as described in Sec. III B, as a function of the applied bias at half filling. Results are shown for both the Hartree-Fock and the GW approximations, following the same loop of forward and reverse bias scans. For weak effective coupling between impurity and leads, for the magnetic solution, one has $\delta\mathcal{E} \approx \mathcal{E}_{\text{imp}} + O(\Gamma)$. Near equilibrium, the magnetic solutions in the forward bias scan show very similar energies, close to the energy of the isolated single-occupied impurity: $\delta\mathcal{E}^{\text{mag}} \sim V_G = -U/2$. However, at the applied bias where the current rapidly increases and the solution changes to nonmagnetic, Hartree-Fock yields an average energy higher than the magnetic one by about $U/4$. On the other hand, the GW approximation shows an average energy change that is much

smaller. Correspondingly, on the reverse bias scan, the bias dependence of the average energy is also much different. While the energy in the Hartree-Fock approximation remains high as the bias approaches zero, the energy in the GW approximation approaches a value that is only higher than the zero-bias magnetic state by about $\Gamma/20$.

We have found that in the strong-interaction regime, there are two distinct self-consistent solutions with the GW approximation. These lead to hysteresis in the calculated I - V curves. However, at zero bias, bistability is forbidden for the Anderson model.^{18,19} Therefore, the states represented by those solutions found in the GW approximation must be unstable with respect to quantum fluctuations that have not been taken into account. The fact that the average energy of the magnetic state is lower than that of nonmagnetic solution is probably an indication of the larger weight of the magnetic solution in the emerging exact many-body state. As the bias is increased away from equilibrium, Fig. 8 shows that the energy difference between nonmagnetic and magnetic configurations also increases in the GW approximation. However, for applied bias larger than about $\Gamma/20$, the energy difference is smaller than the applied bias. This means that at nonzero biases on-shell processes will be possible through which one configuration can decay into the other one (with one electron transferring from one lead to the other to ensure total-energy conservation). We thus expect that, out of equilibrium, the lifetime of the GW bistable states would be even smaller than at equilibrium. Quantum fluctuations between the two degenerate magnetic configurations and the nonmagnetic one will eliminate the hysteresis, and renormalize in a nontrivial way the emerging unique many-body state. Therefore, the hysteresis in the I - V curve is probably another signal that the GW approximation is not representing important aspects of the strong-interaction regime. A calculation of the lifetime of the bistable states found with the GW approximation is beyond the scope of the present work but would be very valuable.

V. SUMMARY

In this work we used the GW approximation to study the role of electron-electron correlation effects in the out-of-equilibrium single impurity Anderson model. We considered the regime with weak level broadening and strong Coulomb interaction, treating the electron-electron interaction with the self-consistent GW approximation for the electron self-energy. We found that the GW approximation accounts for Coulomb blockade effects. The low conductance (blockade) region in gate bias and source-drain bias corresponds to a magnetic solution in the GW approximation. At the edge of the blockade region, the current jumps and the self-consistent solution changes to a nonmagnetic character. The position of the transition and the jump in current are renormalized from the Hartree-Fock values. However, we also found a self-consistent nonmagnetic solution inside the Coulomb blockade region. As a consequence, the GW approximation also predicts an unphysical hysteresis in the I - V characteristics of the system. Outside the blockade region, e.g., where the source-drain bias is high and the magnetic solution is not

stable, we expect that the GW approximation gives a reasonable account of the conductance. However, the jump in current at the edge of the blockade region and the hysteresis inside the blockade region both appear to arise from a first-order-transition-like bistability in the GW approximation. An analysis of the total-energy difference between the magnetic and nonmagnetic solutions suggests that quantum fluctuations beyond the scope of the GW approximation would result in rapid decay of the nonmagnetic solution, eliminating both the sharp jump and the hysteresis.

ACKNOWLEDGMENTS

This work was primarily supported by the Nanoscale Science and Engineering Initiative of the National Science Foundation under NSF Awards No. CHE-0117752 and No. CHE-0641523, and by the New York State Office of Science, Technology, and Academic Research (NYSTAR). This work was partially supported by the National Science Foundation under Grants No. NSF-DMR-0705847 and No. NSF-DMR-0705941, and by the U.S. Department of Energy under Contracts No. DE-AC01-94AL85000, No. DE-AC02-98CH10886, and No. DE-AC02-05CH11231. Sandia is a multiprogram laboratory operated by Sandia Corporation, a Lockheed Martin Co., for the United States Department of Energy.

APPENDIX A: AVERAGE CURRENT THROUGH THE JUNCTION

We start from the Meir-Wingreen expression for the current from the left lead (in units of $e=h=1$) (Ref. 42):

$$\begin{aligned} I_L &= i \int d\omega \text{Tr}\{\Gamma_L(\omega)G^<(\omega) + f_L(\omega)\Gamma_L(\omega)[G^r(\omega) - G^a(\omega)]\} \\ &\equiv \int d\omega J_L(\omega). \end{aligned} \quad (\text{A1})$$

Using that in steady state $I=I_L=(I_L-I_R)/2$, and making use of Eq. (9) and the relation:

$$\begin{aligned} G^r(\omega) - G^a(\omega) &= G^r(\omega)[\Delta_L^r(\omega) + \Delta_R^r(\omega) \\ &\quad + \Sigma^r(\omega) - \text{H.c.}]G^a(\omega), \end{aligned} \quad (\text{A2})$$

one obtains:

$$\begin{aligned} I &= \frac{1}{2} \int d\omega [f_L(\omega) - f_R(\omega)] \text{Tr}\{\Gamma_L(\omega)G^r(\omega)\Gamma_R(\omega)G^a(\omega)\} \\ &\quad + \frac{1}{2} \int d\omega [f_L(\omega) - f_R(\omega)] \text{Tr}\{\Gamma_R(\omega)G^r(\omega)\Gamma_L(\omega)G^a(\omega)\} \\ &\quad + \frac{i}{2} \int d\omega \text{Tr}\{[\Gamma_L(\omega) - \Gamma_R(\omega)]G^r(\omega)\Sigma^<(\omega)G^a(\omega)\} \\ &\quad + \frac{i}{2} \int d\omega \text{Tr}\{[f_L(\omega)\Gamma_L(\omega) - f_R(\omega)\Gamma_R(\omega)]G^r(\omega) \\ &\quad \times [\Sigma^r(\omega) - \Sigma^r(\omega)^\dagger]G^a(\omega)\}. \end{aligned} \quad (\text{A3})$$

In the single impurity Anderson model case, the Green's

functions are symmetric (the off-diagonal elements being simply zero) and the first two terms in Eq. (A3) are equal, with the final expression for the current reading as in Eq. (27).

APPENDIX B: CHANGE IN ENERGY CAUSED BY IMPURITY

For simplicity, we consider eigenstates of the noninteracting isolated junction (energies ϵ_n) and isolated leads (energies ϵ_k). Denoting with g the Green's function of the isolated lead, the difference between the average energy of the total system and the average energy of the isolated leads can be written:

$$\delta\mathcal{E} = \mathcal{E}_{\text{imp}} + \mathcal{E}_{\text{imp-leads}} + \delta\mathcal{E}_{\text{leads}}, \quad (\text{B1})$$

where

$$\mathcal{E}_{\text{imp}} = \frac{1}{2} \sum_n \int \frac{d\omega}{2\pi i} (\omega + \epsilon_n) G_{nn}^<(\omega), \quad (\text{B2})$$

$$\mathcal{E}_{\text{imp-leads}} = \Re \sum_{n,k} \int \frac{d\omega}{2\pi i} H_{0,nk} G_{kn}^<(\omega), \quad (\text{B3})$$

[we made use of the fact that $G^<(\omega)^\dagger = -G^<(\omega)$], and:

$$\delta\mathcal{E}_{\text{leads}} = \frac{1}{2} \sum_k \int \frac{d\omega}{2\pi i} (\epsilon_k + \omega) [G_{kk}^<(\omega) - g_{kk}^<(\omega)]. \quad (\text{B4})$$

The expression for $G_{kn}^<(\omega)$ can be derived rather easily in the present case of noninteracting leads⁴⁸:

$$G_{kn}^<(\omega) = \sum_m g_{kk}^r(\omega) H_{0,km} G_{mn}^<(\omega) + \sum_m g_{kk}^<(\omega) H_{0,km} G_{mn}^a(\omega). \quad (\text{B5})$$

Using

$$\sum_k H_{0,nk} g_{kk}^r(\omega) H_{0,km} = \Delta_{Lnm}^r(\omega) + \Delta_{Rnm}^r(\omega), \quad (\text{B6})$$

and

$$\sum_k H_{0,nk} g_{kk}^<(\omega) H_{0,km} = i f_L(\omega) \Gamma_{Lnm}(\omega) + i f_R(\omega) \Gamma_{Rnm}(\omega), \quad (\text{B7})$$

one arrives at the following expression for $\mathcal{E}_{\text{imp-leads}}$:

$$\begin{aligned} \mathcal{E}_{\text{imp-leads}} &= \Re \int \frac{d\omega}{2\pi i} \text{Tr}\{[\Delta_L^r(\omega) + \Delta_R^r(\omega)] G^<(\omega) \\ &\quad + i[f_L(\omega)\Gamma_L(\omega) + f_R(\omega)\Gamma_R(\omega)]G^a(\omega)\}. \end{aligned} \quad (\text{B8})$$

Using also the fact that the flux of particles coming in and out from the junction is exactly zero in steady states:

$$\int d\omega [J_L(\omega) + J_R(\omega)] = 0, \quad (\text{B9})$$

$$\begin{aligned} \Rightarrow \int d\omega \text{Tr}\{[\Gamma_L(\omega) + \Gamma_R(\omega)]G^<(\omega) - [f_L(\omega)\Gamma_L(\omega) \\ + f_R(\omega)\Gamma_R(\omega)][G^a(\omega) - G^r(\omega)]\} = 0, \end{aligned} \quad (\text{B10})$$

one can ignore taking the real part of the right-hand side of Eq. (B8):

$$\begin{aligned} \mathcal{E}_{\text{imp-leads}} = \int \frac{d\omega}{2\pi i} \text{Tr}\{[\Delta_L^r(\omega) + \Delta_R^r(\omega)]G^<(\omega) \\ + i[f_L(\omega)\Gamma_L(\omega) + f_R(\omega)\Gamma_R(\omega)]G^a(\omega)\}, \end{aligned} \quad (\text{B11})$$

which can be further written as in Eq. (31).

Now let us focus on the expression for $\delta\mathcal{E}_{\text{leads}}$. Similarly to Eq. (B5) one also has

$$\begin{aligned} G_{kk}^<(\omega) = g_{kk}^<(\omega) + \sum_n g_{kk}^r(\omega)H_{0,kn}G_{nk}^<(\omega) \\ + \sum_n g_{kk}^<(\omega)H_{0,kn}G_{nk}^a(\omega). \end{aligned} \quad (\text{B12})$$

Further use of

$$G_{nk}^<(\omega) = \sum_m G_{nm}^<(\omega)H_{0,mk}g_{kk}^a(\omega) + \sum_m G_{nm}^r(\omega)H_{0,mk}g_{kk}^<(\omega), \quad (\text{B13})$$

$$G_{nk}^a(\omega) = \sum_m G_{nm}^a(\omega)H_{0,mk}g_{kk}^a(\omega), \quad (\text{B14})$$

$$g_{kk_{L(R)}}^<(\omega) = f_{L(R)}(\omega)[g_{kk_{L(R)}}^a(\omega) - g_{kk_{L(R)}}^r(\omega)], \quad (\text{B15})$$

$$\begin{aligned} \sum_{k \in L(R)} (\epsilon_k + \omega)H_{0,mk}g_{kk}^r(\omega)g_{kk}^a(\omega)H_{0,kn} \\ = \lim_{\delta \rightarrow 0} \int \frac{d\epsilon}{2\pi} \frac{(\epsilon + \omega)\Gamma_{L(R)nm}(\epsilon)}{(\omega - \epsilon + i\delta)(\omega - \epsilon - i\delta)}, \end{aligned} \quad (\text{B16})$$

allows us to write the expression for $\delta\mathcal{E}_{\text{leads}}$ as

$$\begin{aligned} \delta\mathcal{E}_{\text{leads}} = \frac{1}{2} \int \frac{d\omega}{2\pi i} \text{Tr}\{[S_L(\omega) + S_R(\omega)]G^<(\omega) - [S_L(\omega)f_L(\omega) \\ + S_R(\omega)f_R(\omega)][G^a(\omega) - G^r(\omega)]\} \\ - \frac{1}{2} \left[\int \frac{d\omega}{2\pi i} \text{Tr}\{[F_L(\omega)f_L(\omega) + F_R(\omega)f_R(\omega)]G^r(\omega)\} \right. \\ \left. + \text{H.c.} \right], \end{aligned} \quad (\text{B17})$$

with

$$S_{L(R)nm}(\omega) = \lim_{\delta \rightarrow 0} \int \frac{d\epsilon}{2\pi} \frac{(\omega + \epsilon)\Gamma_{L(R)nm}(\epsilon)}{(\omega - \epsilon + i\delta)(\omega - \epsilon - i\delta)}, \quad (\text{B18})$$

$$F_{L(R)nm}(\omega) = \lim_{\delta \rightarrow 0} \int \frac{d\epsilon}{2\pi} \frac{(\omega + \epsilon)\Gamma_{L(R)nm}(\epsilon)}{(\omega - \epsilon + i\delta)^2}. \quad (\text{B19})$$

The function $S(\omega)$ has a singular part which however does not contribute to $\delta\mathcal{E}_{\text{leads}}$. Indeed, writing

$$\begin{aligned} S_{L(R)nm}(\omega) = \Re F_{L(R)nm}(\omega) + \lim_{\delta \rightarrow 0} \frac{1}{\pi} \int d\epsilon(\omega \\ + \epsilon)\Gamma_{L(R)nm}(\epsilon) \frac{\delta}{(\omega - \epsilon)^2 + \delta^2} \frac{\delta}{(\omega - \epsilon)^2 + \delta^2}, \end{aligned} \quad (\text{B20})$$

the contribution to $\delta\mathcal{E}_{\text{leads}}$ of the second term on the right-hand side of Eq. (B20) is proportional to

$$\begin{aligned} \lim_{\delta \rightarrow 0} \frac{1}{\delta} \int d\omega \text{Tr}\{[\Gamma_L(\omega) + \Gamma_R(\omega)]G^<(\omega) - [f_L(\omega)\Gamma_L(\omega) \\ + f_R(\omega)\Gamma_R(\omega)][G^a(\omega) - G^r(\omega)]\} = 0, \end{aligned} \quad (\text{B21})$$

which vanishes by virtue of the fact that the integral multiplying $\frac{1}{\delta}$ is proportional to the flux of energy coming in and out from the junction, which is exactly zero in steady states:

$$\int d\omega \omega [J_L(\omega) + J_R(\omega)] = 0. \quad (\text{B22})$$

Thus, the expression for $\delta\mathcal{E}_{\text{leads}}$ becomes:

$$\begin{aligned} \delta\mathcal{E}_{\text{leads}} = \frac{1}{2} \int \frac{d\omega}{2\pi i} \text{Tr}\{[\Re F_L(\omega) + \Re F_R(\omega)]G^<(\omega) \\ - [\Re F_L(\omega)f_L(\omega) + \Re F_R(\omega)f_R(\omega)][G^a(\omega) - G^r(\omega)]\} \\ - \Re \int \frac{d\omega}{2\pi i} \text{Tr}\{[F_L(\omega)f_L(\omega) + F_R(\omega)f_R(\omega)]G^r(\omega)\}. \end{aligned} \quad (\text{B23})$$

Noting that the function $F_{L(R)}(\omega)$ is related in a simple way to the energy derivative of $\Delta_{L(R)}^r(\omega)$, one finally arrives at Eqs. (32) and (33).

APPENDIX C: AVERAGE NUMBER OF DISPLACED ELECTRONS IN THE LEADS

In a manner similar to the one described in detail in Appendix B, one can obtain an expression for the average number of electrons displaced in the two leads:

$$\delta N_{\text{leads}} \equiv \sum_k \int \frac{d\omega}{2\pi i} [G_{kk}^<(\omega) - g_{kk}^<(\omega)], \quad (\text{C1})$$

with the final expression reading:

$$\begin{aligned} \delta N_{\text{leads}} = - \int \frac{d\omega}{2\pi i} \text{Tr} \left\{ \left[\frac{d}{d\omega} \Re \Delta_L^r(\omega) + \frac{d}{d\omega} \Re \Delta_R^r(\omega) \right] G^<(\omega) \right. \\ \left. - i \left[f_L(\omega) \frac{d}{d\omega} \Im \Delta_L^r(\omega) + f_R(\omega) \frac{d}{d\omega} \Im \Delta_R^r(\omega) \right] \right\} \\ \times [G^a(\omega) + G^r(\omega)]. \end{aligned} \quad (\text{C2})$$

- ¹J. Park, A. N. Pasupathy, J. I. Goldsmith, C. Chang, Y. Yaish, J. R. Petta, M. Rinkoski, J. P. Sethna, H. D. Abruña, P. L. McEuen, and D. C. Ralph, *Nature* (London) **417**, 722 (2002).
- ²W. Liang, M. P. Shores, M. Bockrath, J. R. Long, and H. Park, *Nature* (London) **417**, 725 (2002).
- ³D. Natelson, *Handbook of Organic Electronics and Photonics* (American Scientific Publishers, Valencia, CA, 2006).
- ⁴C. Toher, A. Filippetti, S. Sanvito, and K. Burke, *Phys. Rev. Lett.* **95**, 146402 (2005).
- ⁵F. B. Anders, *J. Phys.: Condens. Matter* **20**, 195216 (2008).
- ⁶S. Weiss, J. Eckel, M. Thorwart, and R. Egger, *Phys. Rev. B* **77**, 195316 (2008).
- ⁷K. A. Al-Hassanieh, A. E. Feiguin, J. A. Riera, C. A. Busser, and E. Dagotto, *Phys. Rev. B* **73**, 195304 (2006).
- ⁸S. Kirino, T. Fujii, J. Zhao, and K. Ueda, *J. Phys. Soc. Jpn.* **77**, 084704 (2008).
- ⁹L. Mühlbacher and E. Rabani, *Phys. Rev. Lett.* **100**, 176403 (2008).
- ¹⁰M. Schiro and M. Fabrizio, arXiv:0808.0589 (unpublished).
- ¹¹T. Schmidt, P. Werner, L. Mühlbacher, and A. Komnik, *Phys. Rev. B* **78**, 235110 (2008).
- ¹²P. Werner, T. Oka, and A. J. Millis, *Phys. Rev. B* **79**, 035320 (2009).
- ¹³A. Ferretti, A. Calzolari, R. Di Felice, F. Manghi, M. J. Caldas, M. Buongiorno Nardelli, and E. Molinari, *Phys. Rev. Lett.* **94**, 116802 (2005).
- ¹⁴P. Darancet, A. Ferretti, D. Mayou, and V. Olevano, *Phys. Rev. B* **75**, 075102 (2007).
- ¹⁵K. S. Thygesen and A. Rubio, *J. Chem. Phys.* **126**, 091101 (2007).
- ¹⁶K. S. Thygesen and A. Rubio, *Phys. Rev. B* **77**, 115333 (2008).
- ¹⁷K. S. Thygesen, *Phys. Rev. Lett.* **100**, 166804 (2008).
- ¹⁸A. Mitra, I. Aleiner and A. J. Millis, *Phys. Rev. Lett.* **94**, 076404 (2005).
- ¹⁹A. Mitra and A. J. Millis, *Phys. Rev. B* **76**, 085342 (2007).
- ²⁰D. Segal, D. R. Reichman, and A. J. Millis, *Phys. Rev. B* **76**, 195316 (2007).
- ²¹P. W. Anderson, *Phys. Rev.* **124**, 41 (1961).
- ²²L. Hedin and S. Lundqvist, *Solid State Phys.* **23**, 1 (1969).
- ²³B. Kjollerstrom, D. J. Scalapino, and J. R. Schrieffer, *Phys. Rev.* **148**, 665 (1966).
- ²⁴M. S. Hybertsen and S. G. Louie, *Phys. Rev. B* **34**, 5390 (1986).
- ²⁵F. Aryasetiawan and O. Gunnarsson, *Rep. Prog. Phys.* **61**, 237 (1998), and references therein.
- ²⁶W. G. Aulbur, L. Jonsson, and J. W. Wilkins, in *Solid State Physics*, edited by H. Ehrenreich and F. Spaepen (Academic, New York, 2000), p. 2 (and references therein).
- ²⁷A. Stan, N. E. Dahlen, and R. Van Leeuwen, *Europhys. Lett.* **76**, 298 (2006).
- ²⁸M. van Schilfsgaarde, T. Kotani, and S. Faleev, *Phys. Rev. Lett.* **96**, 226402 (2006).
- ²⁹X. Wang, C. D. Spataru, M. S. Hybertsen, and A. J. Millis, *Phys. Rev. B* **77**, 045119 (2008).
- ³⁰J. A. White, *Phys. Rev. B* **45**, 1100 (1992).
- ³¹N. E. Bickers, D. J. Scalapino, and S. R. White, *Phys. Rev. Lett.* **62**, 961 (1989).
- ³²Y. Meir, N. S. Wingreen, and P. A. Lee, *Phys. Rev. Lett.* **70**, 2601 (1993).
- ³³S. Hershfield, John H. Davies, and John W. Wilkins, *Phys. Rev. Lett.* **67**, 3720 (1991).
- ³⁴R. Liu, S.-H. Ke, H. U. Baranger, and W. Yang, *J. Am. Chem. Soc.* **128**, 6274 (2006).
- ³⁵F. D. M. Haldane, *J. Phys. C* **11**, 5015 (1978).
- ³⁶H. Haug and A.-P. Jauho, *Quantum Kinetics in Transport and Optics of Semiconductors* (Springer, Berlin, 1996).
- ³⁷S. Datta, *Electronic Transport in Mesoscopic Systems* (University Press, Cambridge, 1995).
- ³⁸The notation we use throughout Sec. III [except for Eq. (10)] can be easily generalized to the case of a central region with multiple impurity sites and nonoverlapping orbitals by replacing the spin index σ with a generalized index n denoting both the site index and the spin degree of freedom. The generalized notation is used in Appendix B.
- ³⁹C. Spataru and P. Budau, *J. Phys.: Condens. Matter* **9**, 8333 (1997).
- ⁴⁰C. D. Spataru, L. X. Benedict, and S. G. Louie, *Phys. Rev. B* **69**, 205204 (2004).
- ⁴¹P. Pulay, *Chem. Phys. Lett.* **73**, 393 (1980).
- ⁴²Y. Meir and N. S. Wingreen, *Phys. Rev. Lett.* **68**, 2512 (1992).
- ⁴³M. Di Ventra and S. T. Pantelides, *Phys. Rev. B* **61**, 16207 (2000).
- ⁴⁴Throughout Sec. IV A we consider $k_B T=0$ but plots practically undistinguishable from the $k_B T=0$ case can be obtained at small nonzero temperatures, such as $k_B T=0.01$.
- ⁴⁵C. D. Spataru *et al.*, (unpublished).
- ⁴⁶L. P. Kadanoff and G. Baym, *Quantum Statistical Mechanics: Green's Functions Methods in Equilibrium and Nonequilibrium Problems* (Addison-Wesley, New York, 1989).
- ⁴⁷A. A. Abrikosov, *Physics* (Long Island City, N.Y.) **2**, 61 (1965).
- ⁴⁸A.-P. Jauho, N. S. Wingreen, and Y. Meir, *Phys. Rev. B* **50**, 5528 (1994).